



## Specifications

Model	Line Voltage (VAC)	Armature Voltage Range (VDC)	Continuous Armature Current (Amps)	Horsepower Range
PWL440-10-JOG	115 230	0 - 130 0 - 240	10.0	1/4 - 1 1/2 - 2

<b>AC Line Voltage</b> .....	115/230 VAC ± 10%, 50/60 Hz, single phase
<b>Form Factor</b> .....	1.05
<b>Field Voltage with 115 VAC line voltage</b> .....	50 or 100 VDC
<b>with 230 VAC line voltage</b> .....	100 or 200 VDC
<b>Maximum Field Current</b> .....	1 Amp
<b>Acceleration Time Range with 130 VDC armature voltage</b> .....	1 - 10 seconds
<b>with 240 VDC armature voltage</b> .....	1 - 15 seconds
<b>Deceleration Time Range with 130 VDC armature voltage</b> .....	coast to stop - 10 seconds
<b>with 240 VDC armature voltage</b> .....	coast to stop - 19 seconds
<b>Analog Input Voltage Range</b> (Signal must be isolated; S1 to S2)	
<b>with 115 VAC line voltage</b> .....	0 - 2.5 VDC
<b>with 230 VAC line voltage</b> .....	0 - 5 VDC
<b>Input Impedance</b> (S1 to S2).....	50K ohms
<b>Load Regulation</b> .....	1% base speed or better
<b>Speed Range</b> .....	100:1
<b>Vibration (0 - 50 Hz)</b> .....	0.5G maximum
<b>(&gt;50 Hz)</b> .....	0.1G maximum
<b>Ambient Temperature Range</b> .....	10°C - 40°C
<b>Weight</b> .....	7.2 lbs
<b>Safety Certifications</b> .....	UL/cUL Recognized Equipment, file # E132235
	CSA Certified Component, file # LR41380

## Safety Warnings

- **DO NOT INSTALL, REMOVE, OR REWIRE THIS EQUIPMENT WITH POWER APPLIED.** Have a qualified electrical technician install, adjust and service this equipment. Follow the National Electrical Code and all other applicable electrical and safety codes, including the provisions of the Occupational Safety and Health Act (OSHA), when installing equipment.
- **Circuit potentials are at 115 or 230 VAC above earth ground.** Avoid direct contact with the printed circuit board or with circuit elements to prevent the risk of serious injury or fatality. Use a non-metallic screwdriver for adjusting the calibration trim pots. Use approved personal protection equipment and insulated tools if working on this drive with power applied.
- Reduce the chance of an electrical fire, shock, or explosion by using proper grounding techniques, over-current protection, thermal protection, and enclosure. Follow sound maintenance procedures
- **Do not disconnect any of the motor leads from the drive** unless power is removed or the drive is disabled. Opening any one lead while the drive is running may destroy the drive.
- Under no circumstances should power and logic level wires be bundled together.

## Dimensions

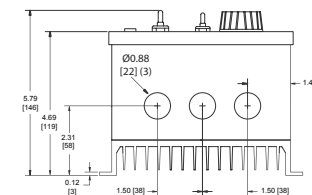
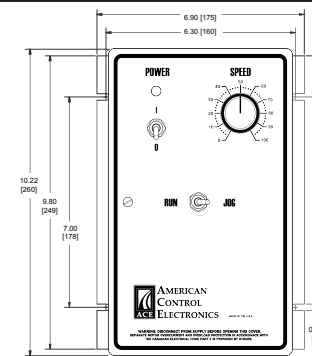

ALL DIMENSIONS IN INCHES [MILLIMETERS]

## Installation

### Mounting

NEMA 4X cased drives come with two 0.88 inch (22 mm) conduit knockout holes at the bottom of the case. The drives may be vertically wall mounted using the four 0.19 inch (5 mm) slotted holes on the attached heat sink. For loads less than 5 amps, the drive may be bench mounted horizontally or operated without mounting.

1. Install the mounting screws.
2. For access to the terminal strip, turn the slotted screw on the front cover counterclockwise until it is free from the case. The right side of the cover is hinged to the case. Pull the slotted screw to open the case.
3. Carefully remove the conduit knockouts by tapping them into the case and twisting them off with pliers.
4. Set the POWER switch to the OFF position before applying AC line voltage.
5. Install conduit hardware through the 0.88 inch (22 mm) knockout holes. Connect external wiring to the terminal block.
6. Grasp the slotted screw and tilt the front cover back into place. Avoid pinching any wires between the front cover and the case.
7. Turn the slotted screw clockwise until tight to secure the front cover.

### Wiring

Use 14 - 16 AWG wire for AC line and motor wiring.

### Shielding Guidelines

As a general rule, ACE recommends shielding of all conductors. If it is not practical to shield power conductors, ACE recommends shielding all logic-level leads. If shielding of logic-level leads is not practical, the user should twist all logic leads with themselves to minimize induced noise. It may be necessary to earth ground the shielded cable. If noise is produced by devices other than the drive, ground the shield at the drive end. If noise is generated by the drive, ground the shield at the end away from the drive. Do not ground both ends of the shield.

### Fusing

PWL440-10 series drives provide on board fusing for the AC line (L1, 230). Fuses are fast acting fuses rated for 15A at 250 VAC.

## Connections

### POWER

#### Line Input

Connect the AC line power leads to terminals L1 and 115 if using 115 VAC line power or to terminals L1 and 230 if using 230 VAC line power.

#### Motor

Connect the DC armature leads to terminals A1 and A2. If the motor does not spin in the desired direction, power down the drive and reverse these connections.

#### Field

At 115 VAC, connect the field leads to terminals F+ and L1 for a 50 VDC field or to F+ and F- for a 100 VDC field. At 230 VAC, connect the field leads to terminals F+ and L1 for a 100 VDC field or to F+ and F- for a 200 VDC field. **Do not make any connections to F+ and F- if using a permanent magnet motor.**

### LOGIC

#### Speed Potentiometer (Pre-wired)

PWL440 series drives are pre-installed with a 10K ohm, 1/4 W potentiometer for speed control.

#### Inhibit

Short the INHIBIT terminals to coast the motor to zero speed. Open the INHIBIT terminals to accelerate the motor to set speed. Twist inhibit wires and separate them from power-carrying wires or sources of electrical noise. Use shielded cable if the inhibit wires are longer than 18 inches (46 cm). If shielded cable is used, ground only one end of the shield to earth ground. Do not ground both ends of the shield. **Do not use the inhibit for emergency stopping.**

ACE offers two accessory plug harnesses for connecting to the inhibit terminals; part number KTW-0001 [18 in (46 cm) leads] and part number KTW-0002 [36 in (91 cm) leads].

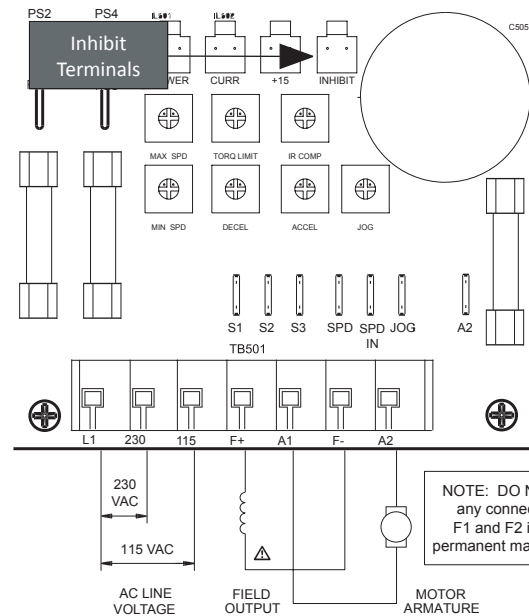

# Startup

## SELECT SWITCHES

### Input Voltage Select (SW501, SW502)

Set the voltage switch SW501 and SW502 to either 115V or 230V to match the AC line voltage.

Input Voltage Select (SW501, SW502)

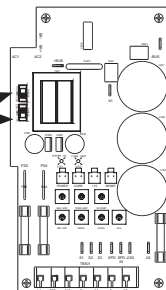

## STARTUP

- Verify that no foreign conductive material is present on the printed circuit board.
- Ensure that all switches are properly set.

1. Turn the speed adjust potentiometer to "0" (full CCW).
2. Set the POWER switch to the ON position.
3. Slowly advance the speed adjust potentiometer clockwise (CW). The motor slowly accelerates as the potentiometer is turned CW. Continue until the desired speed is reached.
4. Set the POWER switch to the OFF position to coast the motor to a stop.

# LEDs

**Current Limit (CURR LIMIT):** Red LED lights whenever the drive reaches current limit.  
**Power (POWER ON):** Green LED lights whenever AC line voltage is applied to the drive.

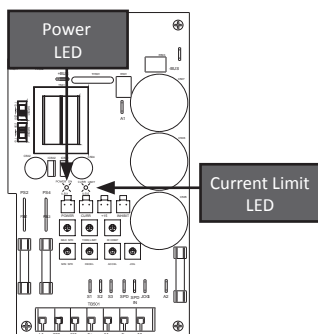

## MODES

### Run Mode

Set the switch on the front cover to RUN to drive the motor at a speed determined by the speed adjust potentiometer on the front cover.

### Jog Mode

Set the switch on the front cover to JOG to drive the motor at a speed determined by the JOG trim pot.

Copyright 2011 by American Control Electronics® - All rights reserved. No part of this document may be reproduced or retransmitted in any form without written permission from American Control Electronics®. The information and technical data in this document are subject to change without notice. American Control Electronics® makes no warranty of any kind with respect to this material, including, but not limited to, the implied warranties of its merchantability and fitness for a given purpose. American Control Electronics® assumes no responsibility for any errors that may appear in this document and makes no commitment to update or to keep current the information in this document.

# Operation

## DECELERATING & STOPPING

### Decelerate to Minimum Speed

The switch shown below may be used to decelerate a motor to a minimum speed. Closing the switch between S1 and S2 decelerates the motor from set speed to a minimum speed determined by the MIN SPD trim pot setting. If the MIN SPD trim pot is set full CCW, the motor decelerates to zero speed when the switch between S1 and S2 is closed. The DECEL trim pot setting determines the rate at which the drive decelerates. By opening the switch, the motor accelerates to set speed at a rate determined by the ACCEL trim pot setting.

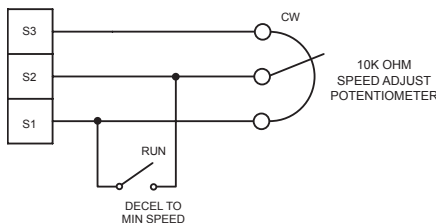

### Decelerate to Zero Speed (Coast)

See INHIBIT in the CONNECTIONS section on page 1 for a description of wiring and connection locations.

### Decelerate to Zero Speed (Dynamic Brake)

Dynamic braking may be used to rapidly stop a motor. For the RUN/BRAKE switch, use a two pole, two position switch rated for at least the armature voltage rating and 150% of the armature current rating. For the dynamic brake resistor, use a 40 watt minimum, high power, wirewound resistor. Sizing the dynamic brake resistor depends on load inertia, motor voltage, and braking time. Use a lower-value, higher-wattage dynamic brake resistor to stop a motor more rapidly. Recommended values are 15 ohms for a 130 VDC motor and 30 ohms for 240 VDC motor.

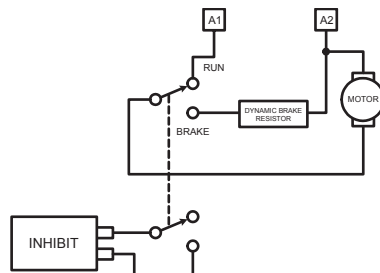

## REVERSING

### Reversing with a Dynamic Brake

A dynamic brake may be used when reversing the motor direction. Use a three pole, three position switch rated for at least the armature voltage rating and 150% of the armature current rating. For the dynamic brake resistor, use a 40 watt minimum, high power, wirewound resistor. Sizing the dynamic brake resistor depends on load inertia, motor voltage, and braking time. Use a lower-value, higher-wattage dynamic brake resistor to stop a motor more rapidly. Recommended values are 15 ohms for a 130 VDC motor and 30 ohms for 240 VDC motor. **The motor must come to a complete stop before changing directions.**

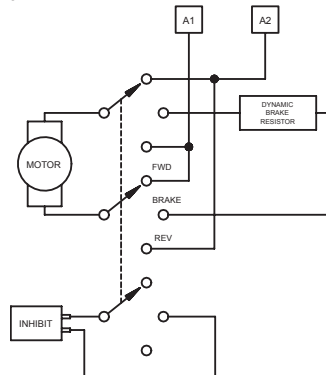

# Calibration

**Minimum Speed (MIN SPD):** The MIN SPD setting determines the minimum motor speed when the speed adjust potentiometer is set for minimum speed. It is factory set for zero speed. To calibrate the MIN SPD:

1. Set the MIN SPD trim pot full CCW.
2. Set the speed adjust potentiometer for minimum speed.
3. Adjust the MIN SPD trim pot until the desired minimum speed is reached or is just at the threshold of rotation.

**Maximum Speed (MAX SPD):** The MAX SPD setting determines the maximum motor speed when the speed adjust potentiometer is set for maximum speed. To calibrate the MAX SPD:

1. Set the MAX SPD trim pot full CCW.
2. Set the speed adjust potentiometer for maximum speed.
3. Adjust the MAX SPD trim pot until the desired maximum speed is reached.

Check the MIN SPD and MAX SPD adjustments after recalibrating to verify that the motor runs at the desired minimum and maximum speed.

**Torque (TORQ LIMIT):** The TORQ LIMIT setting determines the maximum torque for accelerating and driving the motor. To calibrate the TORQ LIMIT:

1. With the power disconnected from the drive, connect a DC ammeter in series with the armature.
2. Set the TORQ LIMIT trim pot to minimum (full CCW).
3. Set the speed adjust potentiometer to maximum speed (full CW).
4. Carefully lock the motor armature. Be sure that the motor is firmly mounted.
5. Apply line power. The motor should be stopped.
6. Slowly adjust the TORQ LIMIT trim pot CW until the armature current is 150% of motor rated armature current. **Continuous operation beyond this rating may damage the motor.**
7. Turn the speed adjust potentiometer CCW.
8. Remove line power.
9. Remove the stall from the motor.
10. Remove the ammeter in series with the motor armature if it is no longer needed.

**IR Compensation (IR COMP):** The IR COMP setting determines the degree to which motor speed is held constant as the motor load changes. To calibrate the IR COMP:

1. Set the IR COMP trim pot full CCW.
2. Increase the speed adjust potentiometer until the motor runs at midspeed without load. A handheld tachometer may be used to measure motor speed.
3. Load the motor armature to its full load armature current rating. The motor should slow down.
4. While keeping the load on the motor, rotate the IR COMP trim pot until the motor runs at the speed measured in step 2. If the motor oscillates (overcompensation), the IR COMP trim pot may be set too high (CW). Turn the IR COMP trim pot CCW to stabilize the motor.
5. Unload the motor.

**Acceleration (ACCEL):** The ACCEL setting determines the time the motor takes to ramp to a higher speed. ACCEL is factory set for the shortest acceleration time (full CCW). To calibrate the ACCEL:

1. Set the speed adjust potentiometer for minimum speed.
2. Set the speed adjust potentiometer for maximum speed. Measure the time it takes the motor to go from minimum speed to maximum speed.
3. If the time measured in step 2 is not the desired acceleration time, turn the ACCEL trim pot CW for a longer acceleration time, or CCW for a shorter acceleration time. Repeat steps 1 through 3 until the acceleration time is correct.

**Deceleration (DECEL):** The DECEL setting determines the time the motor takes to ramp to a lower speed. DECEL is factory set for the shortest deceleration time (full CCW). To calibrate the DECEL:

1. Set the speed adjust potentiometer for maximum speed.
2. Set the speed adjust potentiometer for minimum speed. Measure the time it takes the motor to go from maximum speed to minimum speed.
3. If the time measured in step 2 is not the desired deceleration time, turn the DECEL trim pot CW for a longer deceleration time, or CCW for a shorter deceleration time. Repeat steps 1 through 3 until the deceleration time is correct.

**Jog (JOG):** The JOG setting determines the constant motor speed when the drive is set to Jog mode. To calibrate the JOG:

1. Make sure the drive is in Jog mode. This is done by connecting the SPD IN and JOG terminals.
2. Turn the JOG trim pot until the motor runs at the desired JOG speed.